

# TQC1552

## Smallest (1.2mm<sup>2</sup>), Ultra-Low Power, 32.768 kHz MEMS TCXO

TOKYO QUARTZ CO.,LTD

### Features

- 32.768 kHz  $\pm 5$ ,  $\pm 10$ ,  $\pm 20$  ppm frequency stability options over temp
- World's smallest TCXO in a 1.5 x 0.8 mm CSP
- Operating temperature ranges:
  - 0°C to +70°C
  - -40°C to +85°C
- Ultra-low power: <1  $\mu$ A
- Vdd supply range: 1.5V to 3.63V
- Improved stability reduces system power with fewer network timekeeping updates
- Internal filtering eliminates external Vdd bypass cap and saves space
- Pb-free, RoHS and REACH compliant

### Applications

- Smart Meters (AMR)
- Health and Wellness Monitors
- Pulse-per-Second (pps) Timekeeping
- RTC Reference Clock



### Electrical Characteristics

Parameter	Symbol	Min.	Typ.	Max.	Unit	Condition
<b>Frequency and Stability</b>						
Output Frequency	F <sub>out</sub>	32.768			kHz	
Frequency Stability Over Temperature <sup>[1]</sup> (without Initial Offset <sup>[2]</sup> )	F <sub>stab</sub>	-5.0		5.0	ppm	Stability part number code = E
		-10		10		Stability part number code = F
		-20		20		Stability part number code = 1
Frequency Stability Over Temperature (with Initial Offset <sup>[2]</sup> )	F <sub>stab</sub>	-10		10	ppm	Stability part number code = E
		-13		13		Stability part number code = F
		-22		22		Stability part number code = 1
Frequency Stability vs Voltage	F <sub>vdd</sub>	-0.75		0.75	ppm	1.8V $\pm$ 10%
		-1.5		1.5	ppm	1.5V – 3.63V
First Year Frequency Aging	F <sub>aging</sub>	-1.0		1.0	ppm	T <sub>A</sub> = 25°C, Vdd = 3.3V
<b>Jitter Performance (T<sub>A</sub> = over temp)</b>						
Long Term Jitter				2.5	$\mu$ s <sub>pp</sub>	81920 cycles (2.5 sec), 100 samples
Period Jitter			35		ns <sub>RMS</sub>	Cycles = 10,000, T <sub>A</sub> = 25°C, Vdd = 1.5V – 3.63V
<b>Supply Voltage and Current Consumption</b>						
Operating Supply Voltage	Vdd	1.5		3.63	V	T <sub>A</sub> = -40°C to +85°C
Core Supply Current <sup>[3]</sup>	I <sub>dd</sub>		0.99		$\mu$ A	T <sub>A</sub> = 25°C, Vdd = 1.8V, LVCMOS Output configuration, No Load
				1.52		T <sub>A</sub> = -40°C to +85°C, Vdd = 1.5V – 3.63V, No Load
Power-Supply Ramp	t <sub>Vdd_Ramp</sub>			100	ms	Vdd Ramp-Up 0 to 90% Vdd, T <sub>A</sub> = -40°C to +85°C
Start-up Time at Power-up	t <sub>start</sub>		180	300	ms	T <sub>A</sub> = -40°C to +60°C, valid output
				350		T <sub>A</sub> = +60°C to +70°C, valid output
				380		T <sub>A</sub> = +70°C to +85°C, valid output

#### Notes:

1. No board level underfill. Measured as peak-to-peak/2. Inclusive of 3x-reflow and  $\pm 20\%$  load variation. Tested with Agilent 53132A frequency counter. Due to the low operating frequency, the gate time must be  $\geq 100$  ms to ensure an accurate frequency measurement.
2. Initial offset is defined as the frequency deviation from the ideal 32.768 kHz at room temperature, post reflow.
3. Core operating current does not include output driver operating current or load current. To derive total operating current (no load), add core operating current + output driver operating current, which is a function of the output voltage swing. See the description titled, **Calculating Load Current**.

# TQC1552

Smallest (1.2mm<sup>2</sup>), Ultra-Low Power, 32.768 kHz MEMS TCXO

TOKYO QUARTZ CO.,LTD

## Electrical Characteristics (continued)

Parameter	Symbol	Min.	Typ.	Max.	Unit	Condition
<b>Operating Temperature Range</b>						
Commercial Temperature	Op_Temp	0		70	°C	
Industrial Temperature		-40		85	°C	
<b>LVC MOS Output</b>						
Output Rise/Fall Time	tr, tf		100	200	ns	10-90% (Vdd), 15 pF Load
				50		10-90% (Vdd), 5 pF Load, Vdd ≥ 1.62V
Output Clock Duty Cycle	DC	48		52	%	
Output Voltage High	VOH	90%			V	Vdd: 1.5V – 3.63V. I <sub>OH</sub> = -1 μA, 15 pF Load
Output Voltage Low	VOL			10%	V	Vdd: 1.5V – 3.63V. I <sub>OL</sub> = 1 μA, 15 pF Load

## Pin Configuration

CSP Pin	Symbol	I/O	Functionality
1, 4	GND	Power Supply Ground	Connect to ground. All GND pins must be connected to power supply ground. The GND pins can be connected together, as long as both GND pins are connected ground.
2	CLK Out	OUT	Oscillator clock output. When interfacing to an MCU's XTAL, the CLK Out is typically connected to the receiving IC's X IN pin. The TQC1552 oscillator output includes an internal driver. As a result, the output swing and operation is not dependent on capacitive loading. This makes the output much more flexible, layout independent, and robust under changing environmental and manufacturing conditions.
3	Vdd	Power Supply	Connect to power supply 1.5V ≤ Vdd ≤ 3.63V. Under normal operating conditions, Vdd does not require external bypass/decoupling capacitor(s). For more information about the internal power-supply filtering, see <i>Power-Supply Noise Immunity</i> section in the detailed description. Contact factory for applications that require a wider operating supply voltage range.

### CSP Package (Top View)

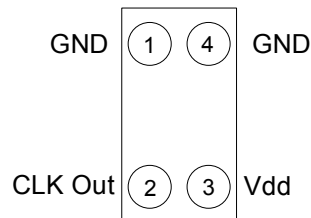

# TQC1552

Smallest (1.2mm<sup>2</sup>), Ultra-Low Power, 32.768 kHz MEMS TCXO

TOKYO QUARTZ CO.,LTD

## System Block Diagram

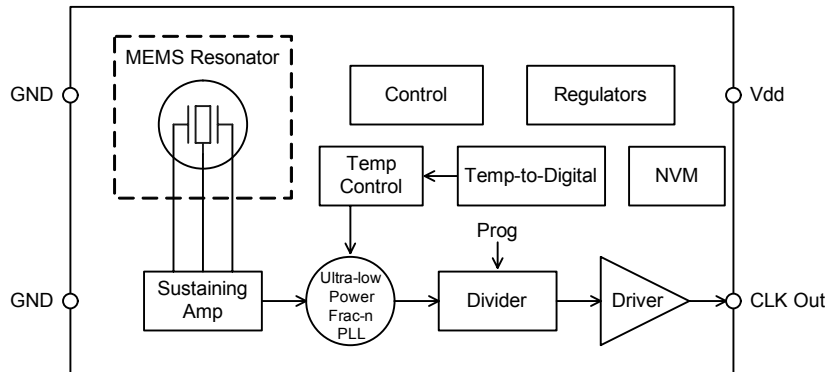

Figure 1.

## Absolute Maximum

Attempted operation outside the absolute maximum ratings cause permanent damage to the part. Actual performance of the IC is only guaranteed within the operational specifications, not at absolute maximum ratings.

Parameter	Test Condition	Value	Unit
Continuous Power Supply Voltage Range (Vdd)		-0.5 to 3.63	V
Short Duration Maximum Power Supply Voltage (Vdd)	≤30 minutes	4.0	V
Continuous Maximum Operating Temperature Range	Vdd = 1.5V - 3.63V	105	°C
Short Duration Maximum Operating Temperature Range	Vdd = 1.5V - 3.63V, ≤30 mins	125	°C
Human Body Model (HBM) ESD Protection	JESD22-A114	3000	V
Charge-Device Model (CDM) ESD Protection	JESD22-A115	750	V
Machine Model (MM) ESD Protection	JESD22-C101	300	V
Latch-up Tolerance	JESD78 Compliant		
Mechanical Shock Resistance	Mil 883, Method 2002	10,000	g
Mechanical Vibration Resistance	Mil 883, Method 2007	70	g
1508 CSP Junction Temperature		150	°C
Storage Temperature		-65°C to 150°C	

# TQC1552

## Smallest (1.2mm<sup>2</sup>), Ultra-Low Power, 32.768 kHz MEMS TCXO

TOKYO QUARTZ CO.,LTD

### Description

The TQC1552 is an ultra-small and ultra-low power 32.768 kHz TCXO optimized for battery-powered applications. TQC's silicon MEMS technology enables the first 32 kHz TCXO in the world's smallest footprint and chip-scale packaging (CSP). Typical core supply current is only 1  $\mu$ A.

TQC's MEMS oscillators consist of MEMS resonators and a programmable analog circuit. Our MEMS resonators are built with TQC's unique MEMS First™ process. A key manufacturing step is EpiSeal™ during which the MEMS resonator is annealed with temperatures over 1000°C. EpiSeal creates an extremely strong, clean, vacuum chamber that encapsulates the MEMS resonator and ensures the best performance and reliability. During EpiSeal, a poly silicon cap is grown on top of the resonator cavity, which eliminates the need for additional cap wafers or other exotic packaging. As a result, TQC's MEMS resonator die can be used like any other semiconductor die. One unique result of TQC's MEMS First and EpiSeal manufacturing processes is the capability to integrate TQC's MEMS die with a SOC, ASIC, microprocessor or analog die within a package to eliminate external timing components and provide a highly integrated, smaller, cheaper solution to the customer.

### TCXO Frequency Stability

The TQC1552 is factory calibrated (trimmed) over multiple temperature points to guarantee extremely tight stability over temperature. Unlike quartz crystals that have a classic tuning fork parabola temperature curve with a 25°C turnover point with a 0.04 ppm/C<sup>2</sup> temperature coefficient, the TQC1552 temperature coefficient is calibrated and corrected over temperature with an active temperature correction circuit. The result is 32 kHz TCXO with extremely tight frequency variation over the -40°C to +85°C temperature range. Contact TQC for applications that require a wider supply voltage range >3.63V, or lower operating frequency below 32 kHz.

When measuring the TQC1552 output frequency with a frequency counter, it is important to make sure the counter's gate time is >100 ms. The slow frequency of a 32kHz clock will give false readings with faster gate times.

### Power Supply Noise Immunity

In addition to eliminating external output load capacitors common with standard XTALs, this device includes special power supply filtering and thus, eliminates the need for an external V<sub>dd</sub> bypass-decoupling capacitor to keep the footprint as small as possible. Internal power supply filtering is designed to reject more than  $\pm$ 150 mV noise and frequency components from low frequency to more than 10 MHz.

### Start-up and Steady-State Supply Current

The TQC1552 TCXO starts-up to a valid output frequency within 300 ms (180 ms typ). To ensure the device starts-up within the specified limit, make sure the power-supply ramps-up in approximately 10 - 20 ms (to within 90% of V<sub>dd</sub>).

During initial power-up, the TQC1552 power-cycles internal blocks, as shown in the power-supply start-up and steady state plot in the Typical Operating Curves section. Power-up and initialization is typically 200 ms, and during that time, the peak supply current reaches 28  $\mu$ A as the internal capacitors are charged, then sequentially drops to its 990 nA steady-state current. During steady-state operation, the internal temperature compensation circuit turns on every 350 ms for a duration of approximately 10 ms.

# TQC1552

## Smallest (1.2mm<sup>2</sup>), Ultra-Low Power, 32.768 kHz MEMS TCXO

TOKYO QUARTZ CO.,LTD

### Calculating Load Current

#### No Load Supply Current

When calculating no-load power for the TQC1552, the core and output driver components need to be added. Since the output voltage swing can be programmed to minimize load current, the output driver current is variable. Therefore, no-load operating supply current is broken into two sections; core and output driver. The equation is as follows:

Total Supply Current (no load) = Idd Core + Idd Output Driver

#### **Example 1: Full-swing LVCMOS**

- Vdd = 1.8V
- Idd Core = 990nA (typ)
- Vout<sub>pp</sub> = 1.8V
- Idd Output Driver: (Cdriver)(Vout)(Fout) = (3.5pF)(1.8V)(32768Hz) = 206nA

Supply Current = 990nA + 206nA = 1.2μA

### Total Supply Current with Load

To calculate the total supply current, including the load, follow the equation listed below.

Total Current = Idd Core + Idd Output Driver + Load Current

#### **Example 2: Full-swing LVCMOS**

- Vdd = 1.8V
- Idd Core = 990nA
- Load Capacitance = 10pF
- Idd Output Driver: (Cdriver)(Vout)(Fout) = (3.5pF)(1.8V)(32768Hz) = 206nA
- Load Current: (10pF)(1.8V)(32768Hz) = 590nA
- Total Current = 990nA + 206nA + 590nA = 1.79μA

# TQC1552

Smallest (1.2mm<sup>2</sup>), Ultra-Low Power, 32.768 kHz MEMS TCXO

TOKYO QUARTZ CO.,LTD

## Typical Operating Curves

(T<sub>A</sub> = 25°C, V<sub>dd</sub> = 1.8V, unless otherwise stated)

Frequency Stability Over Temperature (Pre-Reflow)

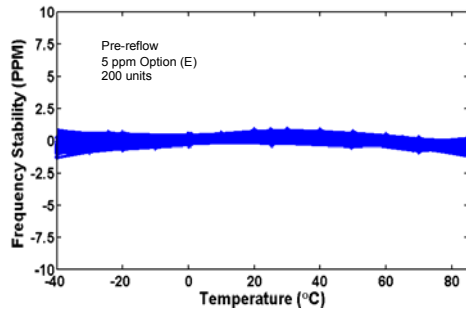

Frequency Stability Over Temperature (Post-Reflow)

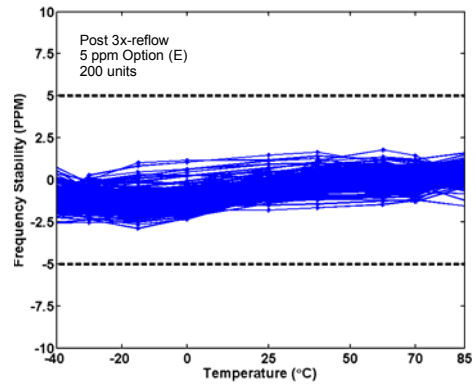

Core Current Over Temperature

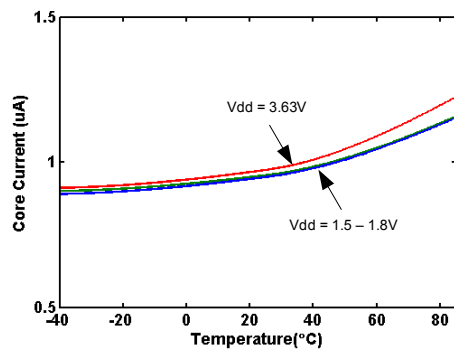

Output Stage Current Over Temperature

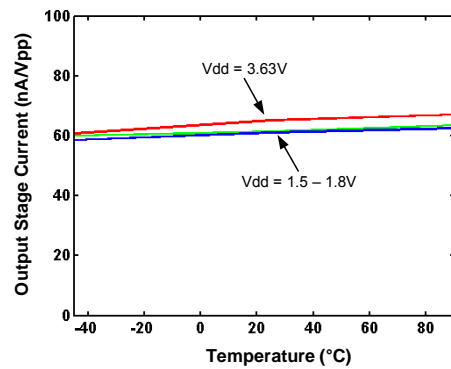

Total Supply Current Over Temperature, LVCMOS (Core + LVCMOS Output Driver, No Load)

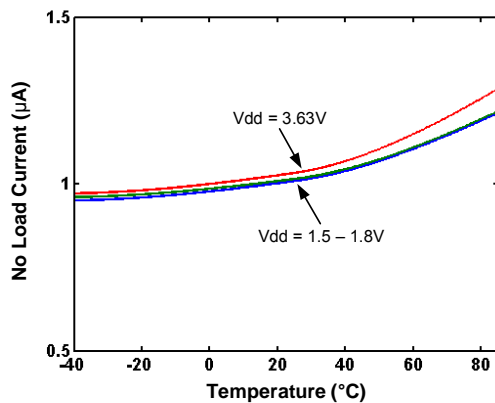

Start-up and Steady-State Current Profile

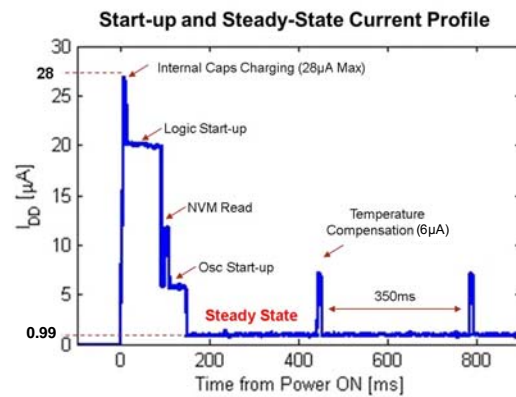

# TQC1552

Smallest (1.2mm<sup>2</sup>), Ultra-Low Power, 32.768 kHz MEMS TCXO

TOKYO QUARTZ CO.,LTD

## Power Supply Noise Rejection (±150mV Noise)

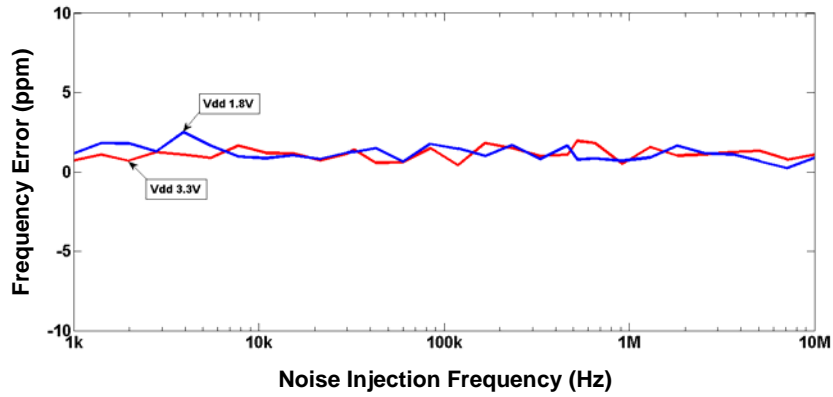

## Temperature Ramp Response

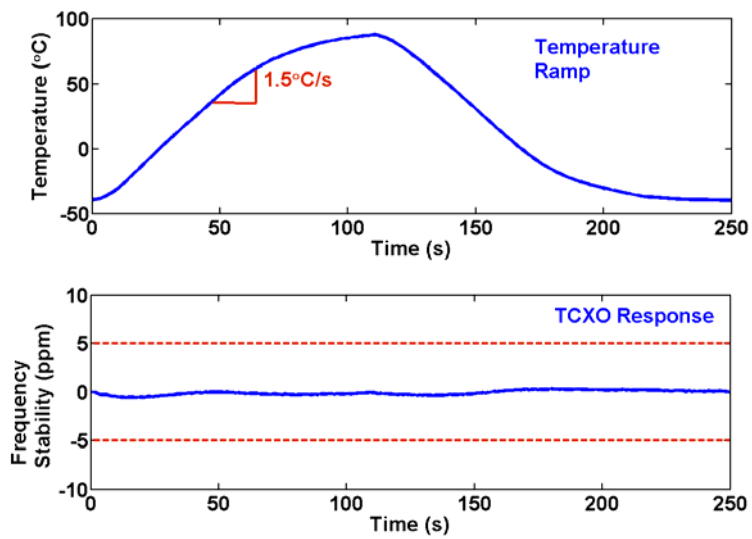

## LVC MOS Output Waveform

(V<sub>swing</sub> = 1.8V, TQC1552AI-JE-DCC-32.768, 10 pF Load)

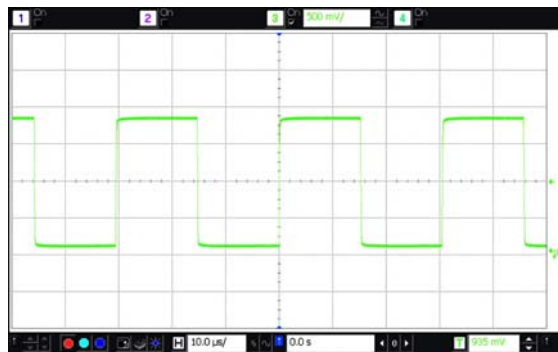

# TQC1552

Smallest (1.2mm<sup>2</sup>), Ultra-Low Power, 32.768 kHz MEMS TCXO

TOKYO QUARTZ CO.,LTD

## Dimensions and Patterns

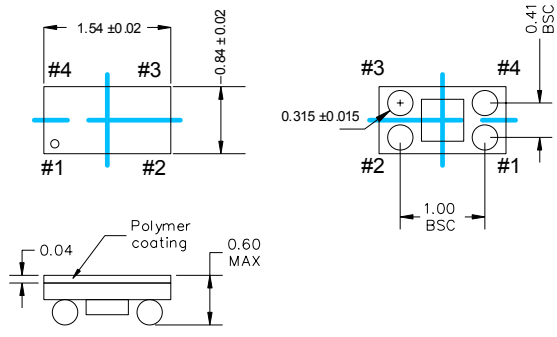
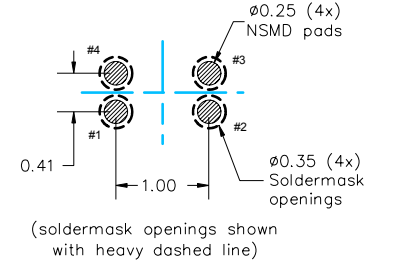
Package Size – Dimensions (Unit: mm)	Recommended Landing Pattern (Unit: mm)
<p><b>1.55 x 0.85 mm CSP</b></p>  <p>0.04 Polymer coating 0.60 MAX</p>	 <p>0.41</p> <p>0.25 (4x) NSMD pads</p> <p>0.35 (4x) Soldermask openings</p> <p>1.00</p> <p>(soldermask openings shown with heavy dashed line)</p> <p><b>Recommend 4-mil (0.1mm) stencil thickness</b></p>



# TQC1552

Smallest (1.2mm<sup>2</sup>), Ultra-Low Power, 32.768 kHz MEMS TCXO

TOKYO QUARTZ CO.,LTD

## Manufacturing Guidelines

- 1) No Ultrasonic Cleaning: Do not subject the TQC1552 to an ultrasonic cleaning environment. Permanent damage or long term reliability issues to the MEMS structure may occur.
- 2) Do not apply underfill to the TQC1552. The device will not meet the frequency stability specification if underfill is applied.
- 3) Reflow profile, per JESD22-A113D.

# TQC1552

Smallest (1.2mm<sup>2</sup>), Ultra-Low Power, 32.768 kHz MEMS TCXO

TOKYO QUARTZ CO.,LTD

## Ordering Information

Part number characters in blue represent the customer specific options. The other characters in the part number are fixed.

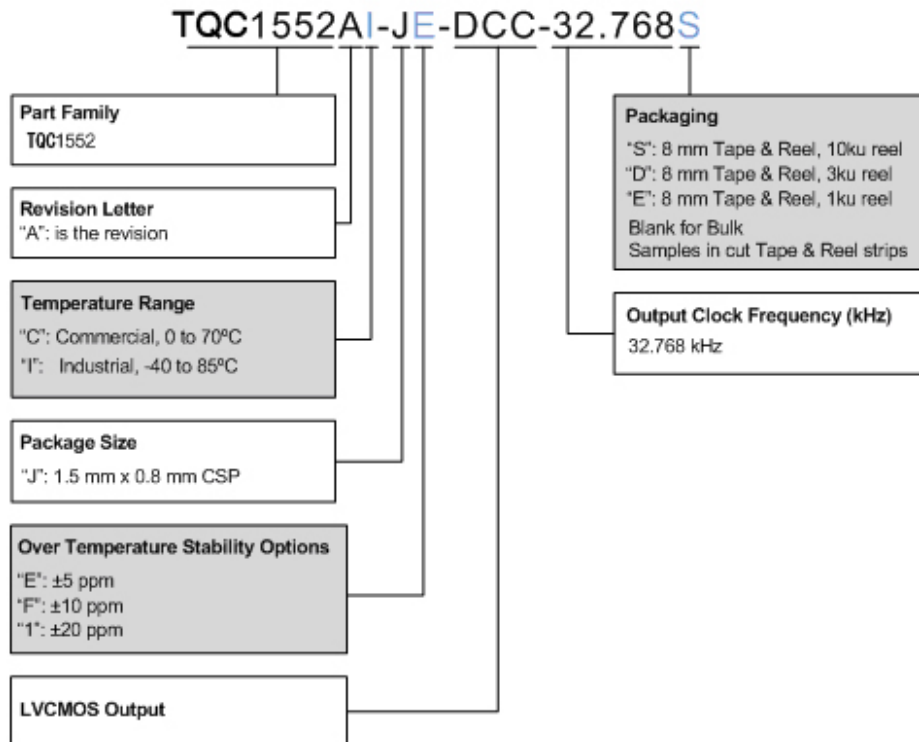

# TQC1552

Smallest (1.2mm<sup>2</sup>), Ultra-Low Power, 32.768 kHz MEMS TCXO

TOKYO QUARTZ CO.,LTD

## Revision History

Version	Release Date	Change Summary
1.0	9/17/14	Rev 0.9 Preliminary to Rev 1.0 Production Release <ul style="list-style-type: none"><li>• Updated start-up time specification</li><li>• Added typical operating plots</li><li>• Removed SOT23 and 2012 SMD package options</li><li>• Added "no underfill" in frequency stability specification condition</li><li>• Added Manufacturing Guidelines section</li></ul>
1.1	10/14/14	<ul style="list-style-type: none"><li>• Improved Start-up Time at Power-up spec</li><li>• Added 5pF LVCMOS rise/fall time spec</li></ul>
1.2	11/10/14	<ul style="list-style-type: none"><li>• Updated 5pF LVCMOS rise/fall time spec</li></ul>
1.3	11/12/15	<ul style="list-style-type: none"><li>• Removed NanoDrive from EC Table and Ordering Info</li></ul>